

HeelGrate® Stainless Steel Floor Drain Vinyl

Specification Data Sheet



Features

- Complies with AS 3996 to Class B for 100mm opening and Class C for 150mm and above and EN 1253 Class C.
- Ideal for all commercial kitchens, schools, shopping centers, hospitals and aged care facilities.

Optional Extras:

- #303636 - Stainless steel strainer basket for 100mm outlet
- #303644 - Stainless steel strainer basket for 150mm outlet

To Specify

The HeelGrate® range of floor drains has been designed to address concerns about possible accidental injury to pedestrians, caused by high heel shoes penetrating grates. The design of the grates also minimises potential problems where tips of crutches, wheelchair wheels or small children's toes could become lodged in the grates.

Code:

303149X - HeelGrate® Stainless Steel Floor Drain Vinyl 150x100BSP with SS Body



A family
owned
Australian
business



Performance Standards & Approvals

- WMTS 040:2016 Lic. WMK02448



Typical Dimensions

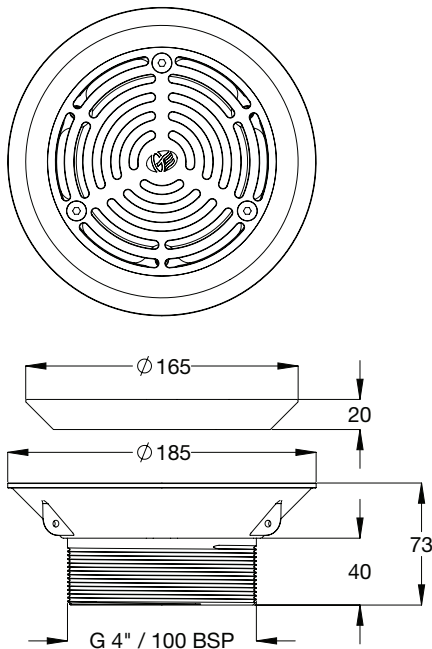

Maintenance & Cleaning

Galvin Specialised products should be cleaned with a soft damp cloth using only mild liquid detergent or soap and water. Do not use cleaning agents containing a corrosive acid, scouring agent or solvents. Do not use cream cleaners, as they are abrasive. Use of unsuitable cleaning agents may damage the surface. Any damage caused in this way will not be covered by warranty.

Regular maintenance should be carried out in accordance with the installation and troubleshooting guides provided with the product, relevant Australian Standards, local authorities and state codes.

As part of maintaining a safe and reliable plumbing system, we recommend tapware and valves are operated on at least a daily basis.

Warranty

Galvin Engineering products are covered under our Manufacturer's Warranty at www.galvinengineering.com.au. Galvin Engineering products must be installed in accordance with the installation instructions and in accordance with AS3500 and the PCA, relevant Australian Standards and local authorities applicable to product being installed. Water and electrical supply conditions must also comply to the applicable national and/or state standards, failing to comply with these provisions may void the product warranty and affect performance of the product.

Whilst all reasonable care has been taken in compiling the information in this document, the designs, dimensions and products shown are indicative only and should not be relied upon without our prior approval. Due to our policy of continuous development, we reserve the right to alter any details of specifications or products without notice. All information, drawings, technical specifications and product designs remains the property of Galvin Engineering Pty Ltd.

Within Australia: **1300 514 074** Outside Australia: P: +61 (0)8 9338 2344
 F: +61 (0)8 9338 2340
sales@galvinengineering.com.au
www.galvinengineering.com.au
 ABN: 78 008 719 382

A business unit of

GalvinEngineering
 the mark of reliability



PERTH | SYDNEY | MELBOURNE | BRISBANE | ADELAIDE | UNITED STATES OF AMERICA | UNITED KINGDOM | NEW ZEALAND